

REVISIONS	
DESCRIPTION	DATE
Release	12 MAR 2015

SBB2-12R

5/16-18 x 1" SS STUD
 5/16-18 SERATED FLANGE NUT

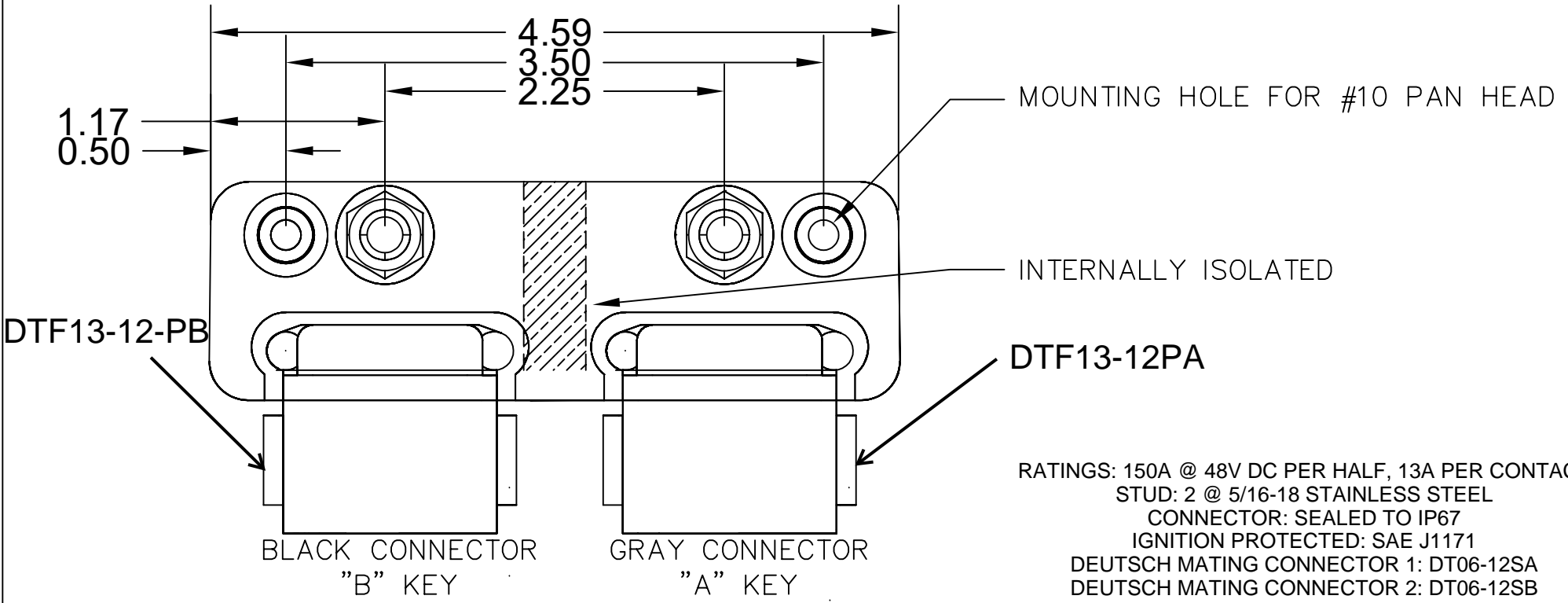
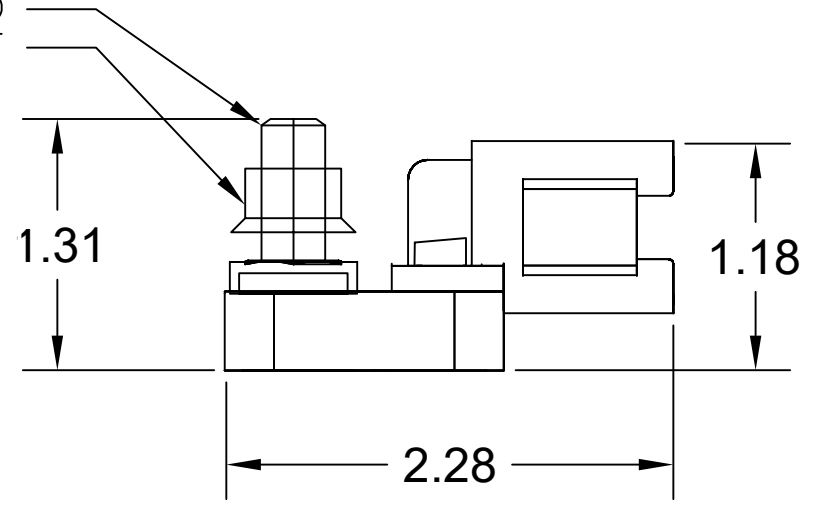

RATINGS: 150A @ 48V DC PER HALF, 13A PER CONTACT
 STUD: 2 @ 5/16-18 STAINLESS STEEL
 CONNECTOR: SEALED TO IP67
 IGNITION PROTECTED: SAE J1171
 DEUTSCH MATING CONNECTOR 1: DT06-12SA
 DEUTSCH MATING CONNECTOR 2: DT06-12SB
 AMPHENOL MATING CONNECTOR 1: AT06-12SA
 AMPHENOL MATING CONNECTOR 2: AT06-12SB
 MOLEX MATING CONNECTOR 1: 93445-6212
 MOLEX MATING CONNECTOR 2: 93445-6221
 BUS MATERIAL: C1100 ELECTROLYTIC COPPER
 BASE: REPTU - INJECTION MOLDED - RED



WWW.SEALED BUSSBAR.COM
 The best protection for your electrical connections

THIS DRAWING IS THE PROPERTY OF SORENSON LIGHTED CONTROLS, INC. A FLORIDA CORPORATION. ALL RIGHTS RESERVED. THIS DRAWING AND INFORMATION CONTAINED MAY NOT BE COPIED OR DISCLOSED TO OTHERS WITHOUT THE WRITTEN PERMISSION OF SORENSON LIGHTED CONTROLS, INC.